



THERMAL SYSTEMS

# Reflow convection soldering is now even more efficient!

New features of the VisionXP+ for best results



**Highlights  
in  
VisionXP+**



VisionXP+  
Convection Soldering

# Number one in the process

## Innovations of VisionXP+

### Rehm develops system technology further

Reflow convection soldering is now even more efficient, more sustainable and easier to maintain! Rehm Thermal Systems presents the VisionXP+ with new features, such as energy-efficient EC fan motors, improvements in the cooling zone, and further developments in design and comprehensive operation data collection.

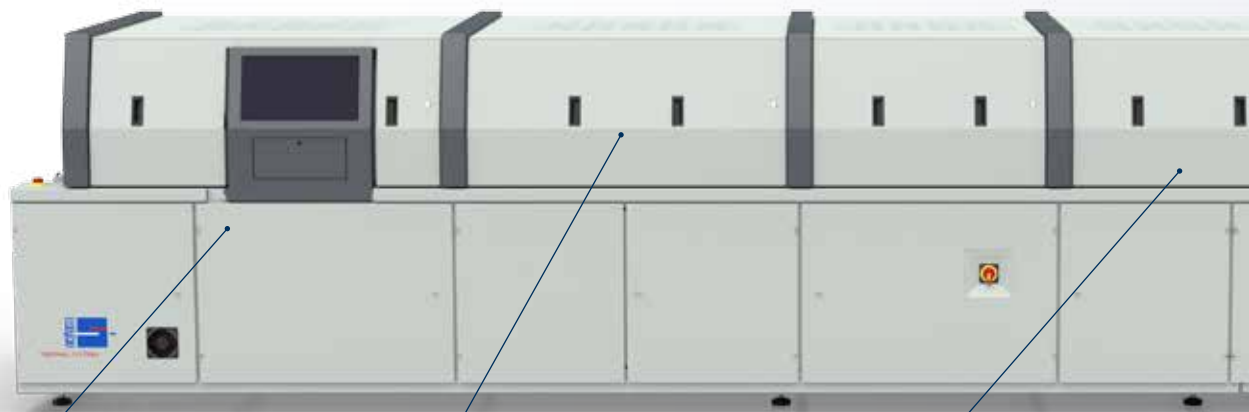

#### 1. New PC swivel arm

The new PC swivel arm with an adapted look makes the VisionXP+ not only more modern and robust but also a great deal more flexible. The new design means that the PC arm protrudes less, can be effectively integrated technically and is variably adjustable. One further benefit is the simple access to the inlet area.

#### 2. Efficient EC fan motors

The use of efficient EC fan technology is one further highlight. The integrated motor electronics of each individual fan can be adjusted individually. This enables operation data, such as speeds, motor temperatures and electric power characteristic values, to be read out via a bus system (Industry 4.0). Traceability is therefore possible thanks to improved process control. Further benefits of the new EC motors include a finer profiling at a lower noise level and minimal energy consumption. There is no need for a frequency converter.

#### 3. Vacuum chamber upper section

As a further feature, it is now possible to open the vacuum module for maintenance purposes at the same time as the process chamber. Inspections and service activities are achieved more simply and even faster.

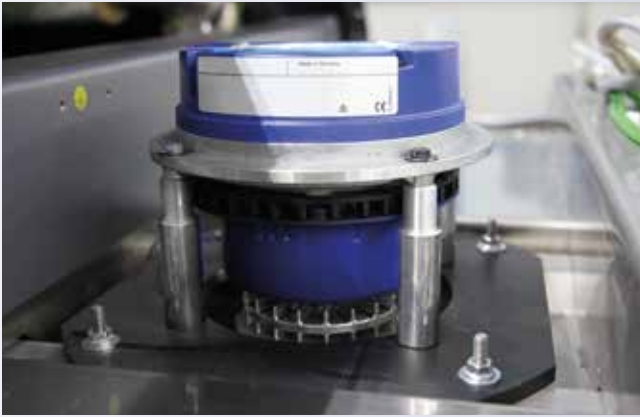

Efficient EC fan motors for comprehensive operation data collection

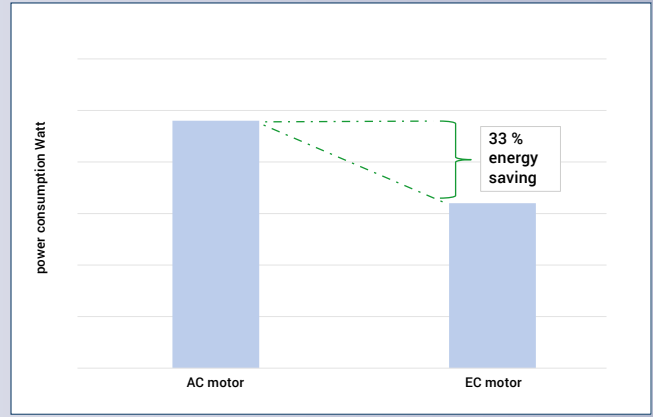

Comparison of AC and EC motors: approximately 33 % energy savings

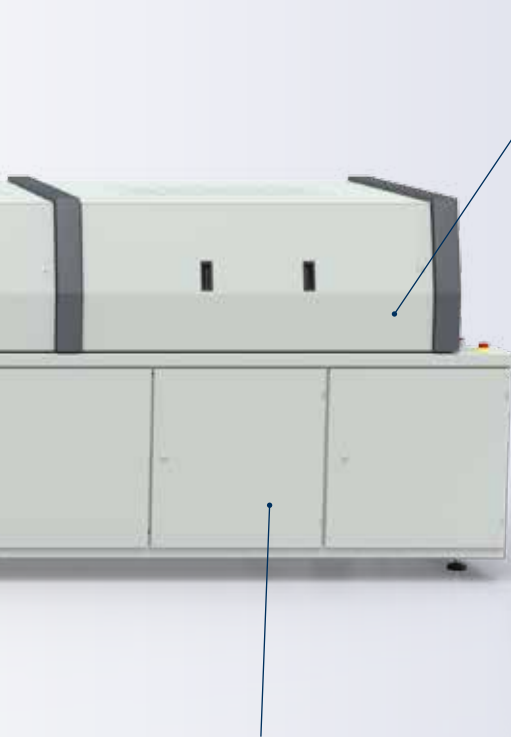

#### 5. Efficiency of the cooling zone

The new cooling zone has several extraction points for the process gas. The cooler filter units are arranged so that they are more compact; the energy consumption can be reduced and the cooling performance improved. The maintenance cycles may also be extended as a result.



#### 4. Integrated vacuum pump

The VisionXP+ allows for voidfree reflow soldering processes and ensures better quality of the soldering points. The vacuum pump is practically integrated directly in systems from Rehm. This saves space and makes the systems easier to inspect.



Integrated vacuum pump



THERMAL SYSTEMS



## Rehm Worldwide

As a leading manufacturer of innovative thermal system solutions we have customers on every continent. With our own locations in Europe, America and Asia as well as 27 agencies in 24 countries we are able to serve the international markets quickly and to offer outstanding on-site service – worldwide and round the clock!

- Location
- Production facility
- Representation



### Rehm Thermal Systems GmbH

Leinenstrasse 7  
89143 Blaubeuren, Germany

T +49 73 44 - 96 06 0 | F +49 73 44 - 96 06 525  
info@rehm-group.com | www.rehm-group.com